

HEAVY DUTY FRAME AND COVER SHALL BE EQUAL TO PATTERN NO. 1200 AS MANUFACTURED BY THE CAMPBELL FOUNDRY COMPANY, HARRISON, N.J. AND SHALL BE MADE IN U.S.A. SEE NOTE 1.

TOP OF CASTING TO BE 1/4" BELOW FINISH GRADE IN ASPHALT PAVEMENT, FLUSH TO FINISH GRADE ELSEWHERE

ADJUST TO REQUIRED GRADE WITH MINIMUM TWO COURSES OF BRICK, MASONRY OR REINFORCED CONCRETE GRADING RINGS

O-RING RUBBER GASKET JOINTS

MORTAR JOINT (INSIDE & OUTSIDE)

INVERT CAN BE BRICK, MASONRY OR CLASS "A" CONCRETE

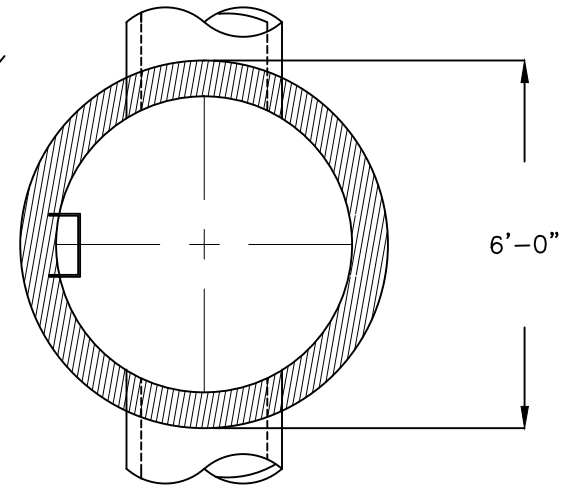
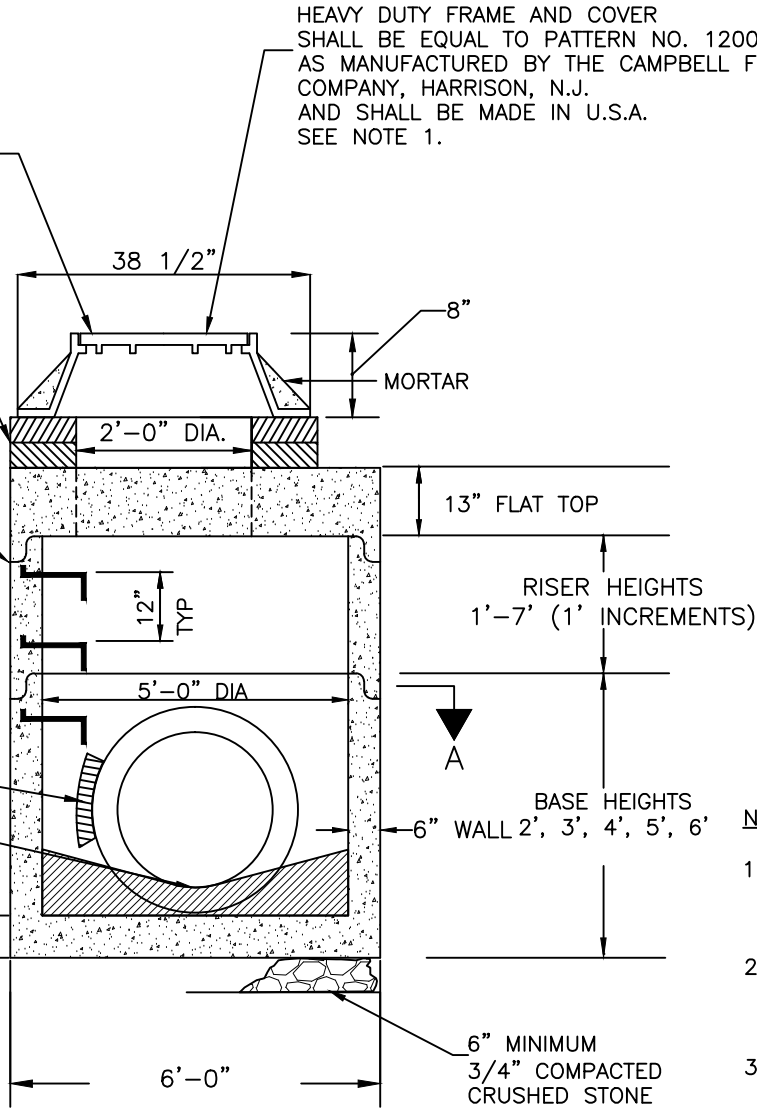

SECTION A-A

SECTIONAL ELEVATION

NOTES:

1. MANHOLES SHALL HAVE LETTERS "DRAIN" CAST ON THE COVERS AND FRAME AND THE COVER SHALL BE MADE IN U.S.A.
2. ALL INTERIOR AND EXTERIOR SURFACES OF MANHOLE GRADE ADJUSTMENT COURSES SHALL BE COVERED WITH 1/4" TO 3/8" MASONRY CEMENT PLASTER.
3. MANHOLE STEPS SHALL BE EQUAL TO PATTERN NO. 2593 AS MANUFACTURED BY THE CAMPBELL FOUNDRY COMPANY, HARRISON, N.J. (ALIGN VERTICALLY)

SCALE = N.T.S.

STANDARD CONSTRUCTION DETAIL

5' DIA. STORM DRAIN
PRECAST CONCRETE MANHOLE

TOWN OF GREENWICH, CONNECTICUT
ENGINEERING DIVISION
DEPARTMENT OF PUBLIC WORKS